



The MTF-E series has been designed for use in industrial processes in environments with a potentially explosive atmosphere, caused by gas and dusts, in compliance with ATEX Directive (94/9/CE). The MTF-E series is equipped with special cable glands to ATEX Ex e II standards and is characterised by two brass plates.

In particular, the MTF-E series can be used in areas 1 and 2 (gas) and areas 21 and 22 (dusts) according to the layout and following features:

Category: II 2 G,D

Level of protection: Ex e II, tD A21 IP66

Temperature class:

Gas: T3 (200°C) o T4 (135°C)

Dusts: 120°C

EC certificate: LCIE 06 ATEX

Areas of use: 1, 2, 21, 22

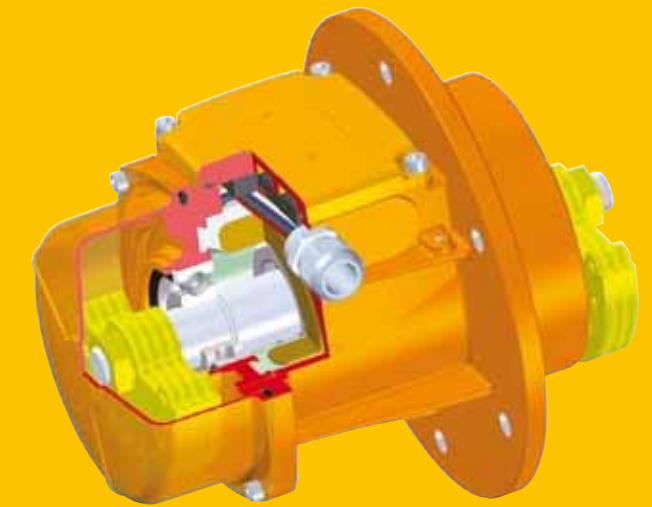

Technical features

Power supply

Three-phase voltage from 220V to 690V, 50Hz or 60Hz; suitable for use with an inverter from 20Hz to the base frequency with constant torque load profile.

Polarity

2 or 4 poles.

Conformity with European Directives

ATEX 94/9/CE; Electromagnetic Compatibility 89/336/CE

Reference Regulations

IEC/EN 60079-0, IEC/EN 60079-7, IEC/EN 61241-0, IEC/EN 61241-1, EN 60034-1, EN 50081-1, EN 50081-2, EN 50082-1, EN 50082-2.

Controls

The components that affect protection are 100% accurately controlled and recorded. The vibrators undergo 100% dynamic tests on the bench.

Functioning

Continual service (S1) at maximum declared centrifugal force and electric power.

Centrifugal force

Range extended up to 1180 Kgf. (11.6 KN), with centrifugal force adjustable from 0 to 100%.

Mechanical protection

IP 66 according to IEC 529, EN 60529; mechanical protection is ensured in the mounting pha-

se of the vibrator onto the vibrating machine, by introducing the special seal into the seat on the coupling flange.

Shock-proof protection

IK 08 according to IEC 68, EN 50102.

Insulation class

Class F (155°C).

Tropicalization

Standard on all vibrators, with vacuum impregnation up to size AF 30 and 35, with "drop by drop" trickle system for larger sizes.

Environmental temperature

From -10°C to +40°C, on request it is possible to have vibrators for max. environmental temperatures of 55°C. On request special greases for temperatures less than -10°C.

Vibrator heat protection

On demand with PTC rated thermistor heat detectors 130°C (DIN 44081-44082). Also on request thermistors with different temperatures and anti-condensation heaters.

Fixing of the vibrator

In all positions and therefore without restriction.

Lubrication

All vibrators are lubricated in the factory and do not require further lubrication if used in normal operating conditions. In heavy duty operating conditions periodical re-lubrication may be applied to size 40.

Electrical connection box

The size guarantees passage of tools used for fixing the vibrator to the vibrating machine. The electrical connection must be carried out using the relative connectors inserted inside the connection box.

Special shaped terminals allow to fix the power supply cable, protecting it from loosening.

Electric motor

Three-phase asynchronous type. Designed for maximum starting torques and torque curves adapt for the specific requirements of vibrating machines. Insulated windings using vacuum encapsulating up to size 30; using the "drop by drop" trickle system with class H resin for size 40. The rotor is die cast aluminium.

Casing

In high-tensile aluminium alloy. An external earthing screw is located on the casing as prescribed by Regulation IEC/EN 60079-0

Bearing flange

Constructed in cast iron (ductile or grey) or in aluminium with steel bearing seat. The geometry of the flange transmits the load to the casing uniformly.

Bearings

The lower and upper bearings have been studied to support the relative load and therefore they have a particular geometry, especially designed and made for Italtvibras.

Motor shaft

In treated steel alloy (Isothermic hardening) resistant to stress.

Eccentric weights

Allow greater adjustment of the centrifugal force, with phase shift of the lower weight assembly with respect to the upper group. This adjustment is eased by a graduated scale, which expresses the centrifugal force as a percentage of the maximum centrifugal force.

Weight covers

In aluminium alloy, mounted only on the lower side. The flange side does not have weight cover. Size 40 is supplied without weights covers on both sides.

Painting

Electrostatic surface treatment based on polymerised epoxy polyester powder in oven at 200°C. Tested in salt spray for 500 hours.

Other features

The MTF-E series is equipped with a special cable-holder in compliance with ATEX Ex e II Regulations and is characterised by two plates.

Certifications

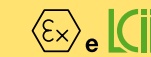

II 2 G, D – Class Ex e II T4/T3 tD A21 IP 66. IEC/EN 60079-0, IEC/EN 60079-7, IEC/EN 61241-0, IEC/EN 61241-1. Certificate n° LCIE 06 ATEX



GGTN Permit and Gost-R certificate for increased safety Ex e: GOST R 51330.0-99, GOST R 51330.8-99, GOST R IEC 61241-1-1-99.



Comply with the applicable European Union directives

2 poles - 3000/3600 rpm

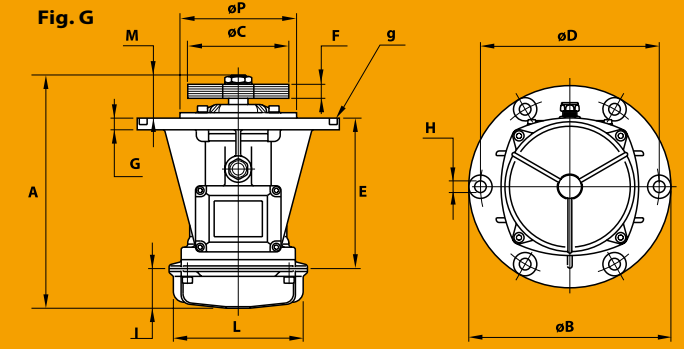

	Description			Mechanical specifications						Electrical specifications						Dimensional specifications (mm)																				
	Code	Type	SIZE	Centrifugal force				Weight		Temp. class (G)	Temp. class (D)	Max input power W		Power rating W		Max. current A		t _E (s)	I _a /I _n	Type	Fig.	A	øB	Holes				E	F	G	I	L	M	øP	Cable entry thread	Seal g
				50 Hz	60 Hz	50 Hz	60 Hz	50 Hz	60 Hz			50 Hz	60 Hz	50 Hz	60 Hz	400 V 50 Hz	460 V 60 Hz							øD	øH	N°										
three-phase	6E0369	MTF 3/200E-S02 ◦	01	212	221	2.08	2.17	7.50	7.30	T3	120°C	180	180	120	120	0.33	0.33	30	2.68	MTF 3/200E-S02 ◦	G	224.5	211.5	100	188	12	4	150	21 (50Hz) 18 (60Hz)	10	58	103	22.5	-	M20x1,5	OR 4650
	6E0370	MTF 3/300E-S02	10	303	296	2.97	2.90	11.2	10.9	T3 T4	120°C	260 230	270 230	210 172	210 172	0.57 0.48	0.50 0.41	18 12	3.50 4.20	MTF 3/300E-S02	G	247	215	110	187	12	4	177	18 (50Hz) 12 (60Hz)	13	54	127	22	-	M20x1,5	OR 4625
	6E0378	MTF 3/500E-S02	20	643	602	6.31	5.91	15.0	14.1	T3 T4	120°C	500 350	500 360	300 210	300 210	0.76 0.57	0.67 0.50	12 8	4.20 5.60	MTF 3/500E-S02	G	279.5	245	150	205	12	6	130	18 (50Hz) 12 (60Hz)	12	65	145	90.5	162	M25x1,5	OR 4700
	6E0380	MTF 3/800E-S02	30	785	754	7.70	7.40	17.0	16.5	T3 T4	120°C	550 390	570 400	405 290	405 290	0.95 0.72	0.83 0.64	12 8	4.20 5.52	MTF 3/800E-S02	G	301	260	150 (50Hz) 132 (60Hz)	230	15	6	182	18	15	63	170	56	150	M25x1,5	OR 4800
	6E0285	MTF 3/1100E-S90 ▲	40	1180	1132	11.6	11.1	26.0	25.0	T4	120°C	830	910	660	660	1.43	1.25	6	7.30	MTF 3/1100E-S90 ▲	G	383	279	145	254	14	4	-	31 (50Hz) 21 (60Hz)	17.5	57.5	-	63	229	M25x1,5	-

4 poles - 1500/1800 rpm

	Description			Mechanical specifications						Electrical specifications						Dimensional specifications (mm)																				
	Code	Type	SIZE	Centrifugal force				Weight		Temp. class (G)	Temp. class (D)	Max input power W		Power rating W		Max. current A		t _E (s)	I _a /I _n	Type	Fig.	A	øB	Holes				E	F	G	I	L	M	øP	Cable entry thread	Seal g
				50 Hz	60 Hz	50 Hz	60 Hz	50 Hz	60 Hz			50 Hz	60 Hz	50 Hz	60 Hz	400 V 50 Hz	460 V 60 Hz							øD	øH	N°										
three-phase	6E1403	MTF 15/200E-S02	10	212	213	2.08	2.09	14.0	13.2	T3	120°C	170	175	94	95	0.39	0.40	28	2.34	MTF 15/200E-S02	G	292.5	215	114	187	12	4	177	48 (50Hz) 40 (60Hz)	13	77	127	44.5	-	M20x1,5	OR 4625
	6E1405	MTF 15/400E-S02	20	412	411	4.04	4.03	20.6	19.8	T3 T4	120°C	300 285	320 270	200 180	230 200	0.57 0.52	0.52 0.46	18 16	3.33 3.63	MTF 15/400E-S02	G	335.5	245	130	205	12	6	130	59 (50Hz) 42 (60Hz)	12	93	145	118.5	162	M25x1,5	OR 4700
	6E1406	MTF 15/550E-S02	20	552	592	5.42	5.81	22.0	20.6	T3 T4	120°C	300 285	320 270	200 180	230 200	0.57 0.52	0.52 0.46	18 16	3.33 3.63	MTF 15/550E-S02	G	376.5	245	130	205	12	6	130	79 (50Hz) 59 (60Hz)	12	114	145	138.5	162	M25x1,5	OR 4700
	6E1407	MTF 15/700E-S02	30	720	759	7.06	7.45	24.2	22.7	T3 T4	120°C	460 360	500 420	310 240	380 210	0.86 0.72	0.85 0.70	17 12	3.50 4.20	MTF 15/700E-S02	G	380.5	260	154	230	15	6	182	59 (50Hz) 46 (60Hz)	15	106	170	92.5	150	M25x1,5	OR 4800
	6E1280	MTF 15/1100E-S90 ▲	40	1045	982	10.3	9.63	36.0	31.4	T3 T4	120°C	900 630	950 700	660 460	730 505	1.38 1.05	1.32 1.00	13 8	4.00 5.36	MTF 15/1100E-S90 ▲	G	426	279	190	254	14	4	-	49	17.5	57.5	-	84.5	229	M25x1,5	-

* Working moment = 2 x static moment. ◦ Available only in versions 127/220V 50Hz three-phase, 200/346V 60Hz three-phase and 210/363V 60Hz three-phase.

▲ Shaft extension. t_E (s) = set time t_E from IEC/EN 60079-7. I_a/I_n = ratio between start-up current and maximum current.

Weight adjustment

Frontal fixing weights

Clamp fixing weights



Graduated disks for upper and lower weight group phase shift

Regulation between upper and lower weight groups

Single weight phase shift

Force line direction

Mass group relative regulation

