

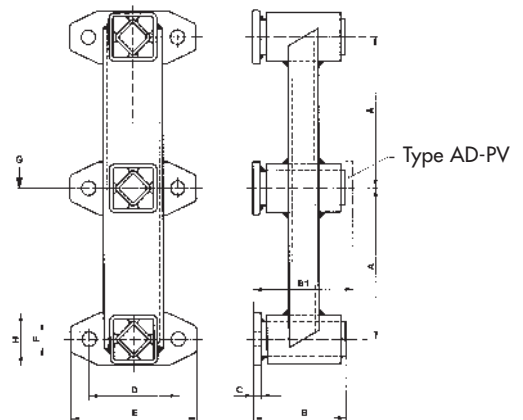

## Double Suspension

## Type AD-P



Type AD-PV with offset flanges

Art. No.	Type	G			$n_{err}$	sw	$c_d$	A	B	C	D	E	F	H	Weight in kg
		K=2	K=3	K=4											
07 111 001	AD-P 18	150	120	100	640	17	22	100	62	5	60	85	9.5	35	1.21
07 111 002	AD-P 27	300	240	200	590	21	32	120	73	5	80	110	11.5	45	2.55
07 111 003	AD-P 38	600	500	400	510	28	45	160	95	6	100	140	14	60	5.54
07 111 004	△ AD-P 45	1200	1000	800	450	35	50	200	120	8	130	180	18	70	8.51
07 111 005	△ AD-P 50	1800	1500	1200	420	44	55	250	145	10	140	190	18	80	12.90

Art. No.	Type	G			$n_{err}$	sw	$c_d$	A	B <sub>1</sub>	C	D	E	F	H	Weight in kg
		K=2	K=3	K=4											
07 121 001	AD-PV 18	150	120	100	640	17	22	100	68	5	60	85	9.5	35	1.21
07 121 002	AD-PV 27	300	240	200	590	21	32	120	80	5	80	110	11.5	45	2.55
07 121 003	AD-PV 38	600	500	400	510	28	45	160	104	6	100	140	14	60	5.54
07 121 004	△ AD-PV 45	1200	1000	800	450	35	50	200	132	8	130	180	18	70	8.51
07 121 005	△ AD-PV 50	1800	1500	1200	420	44	55	250	160	10	140	190	18	80	12.90

G = max. loading in N per suspension

K = oscillating machine factor

$n_{err}$  = max. frequency in  $min^{-1}$  at  $\pm 10^\circ$ , from zero  $\pm 5^\circ$

sw = max. amplitude in mm

$c_d$  = dynamic spring value in N/mm at  $\pm 5^\circ$ , in frequency range 300–600  $min^{-1}$

Suspensions for higher loads or asymmetric distances between centres A available on request

△ available on request

### Material Structure

Rocker arm made out of welded steel structure; inner square and fixation flange in steel.

### Guidelines for Fitting

The rocker angle  $\beta$  of the rocker suspensions is  $10^\circ$  to  $30^\circ$  according to experience, depending largely on the conveying performance and the material to be moved. To secure optimal performance the troughs, screens etc. must be designed stiff and rigid. Types AD-P are intended for flange mounting. Types AD-C for central fixing.

